

HE360 Powered Flow-Through Humidifier

OWNER'S GUIDE



WELCOME...

...to the comfortable world of humidified air. With your Honeywell humidifier you will notice a decrease in dry skin, scratchy throats and irritated nasal passages which aggravate allergies and asthma. You've also taken the first step to stopping the "zapping" created by walking on your carpet and touching the TV, computer, metal door knob or your pet. You can even put away your glue bottle because your furniture and woodwork will stop drying out. Congratulations! You have just made a great investment in your home comfort.

TABLE OF CONTENTS

Operating Your Humidifier	4
How Your Humidifier Works	4
Maintenance Instructions	5
Every 1 To 3 Months	5
End of Humidification Season	6
Checking the Humidifier for Proper Operation	6
Troubleshooting	6
Perfect Climate® Controls for Added Comfort and Convenience	7
Warranty	8

OPERATING YOUR HUMIDIFIER

Your Honeywell humidifier is controlled by a humidistat that is installed either on an interior wall in the living area or on the cold air return. Choose the humidistat setting from the table below and adjust the humidistat to the recommended setting.

At Outside Temperature	Recommended Setting	At Outside Temperature	Recommended Setting
-20°F	15	+10°F	30
-10°F	20	+20°F	35
0°F	25	Above 20°	40

NOTE: When you review the table, the settings may appear to be incorrect. As the outside temperature drops, the recommended setting is lowered to accommodate for effects of dew point. These settings should reduce the accumulation of moisture and ice on your windows and in other areas of your home.

Refer to the following table if your humidistat uses words instead of numbers for the setting.

At Outside Temperatures	Recommended Setting
-20°F	Low
0°F	Low-Medium
+10°F	Medium
+20° or above	Medium-High

Some indoor activities such as cooking, showering and clothes drying can cause excessive levels of humidity and start the accumulation of moisture on your windows.

NOTE: If this condition persists for more than a few hours, set the humidistat to the lowest setting to turn off the humidifier. If the condition does not improve, the home should be ventilated to remove the moisture.

Your humidistat monitors the relative humidity and activates the humidifier accordingly. The humidifier has a water supply that dispenses water evenly over a humidifier pad. The warm dry air, from the furnace, passes over the humidifier pad and picks up the moist air to circulate it through your home.

Humidified air feels warmer and more comfortable so you may be able to lower your thermostat heating setpoint which saves money on your heating fuel bills. The end result, your humidifier gives you a comfortable home that is also energy efficient.

HOW YOUR HUMIDIFIER WORKS

Your Honeywell humidifier uses the principle that vapor (evaporated water) is created when warm air blows over a water soaked area. As the vapor circulates, the relative humidity rises.

MAINTENANCE INSTRUCTIONS

A regular maintenance program prolongs the life of your humidifier and provides a more comfortable home. Frequency of cleaning will depend on the condition of your water.

The humidifier can use hard or soft water. Hard water will leave mineral deposits that are more difficult to clean, but the frequency of cleanings will be less than with soft water. Soft water deposits are easier to remove, but the humidifier needs to be cleaned more often when using soft water.

Use the following steps to clean your Honeywell humidifier:



WARNING

Serious Personal Injury Hazard.
Can cause electrical shock and injury from moving parts.

Disconnect power and shut off water supply before removing cover.

IMPORTANT

Never oil any part of the humidifier.

Every 1 to 3 Months (depending on water quality)

1. Disconnect the power and turn off the humidifier water supply.
2. Remove the humidifier cover by unplugging the connector and loosening thumb screw. Grasp the cover near the bottom and pull toward you.
3. Remove the humidifier pad assembly from the humidifier by grasping the top of the tray and pulling it towards you.
4. Lift the tray off the pad.
5. Gently pinch the water nozzle catches inwards until you can lift the water nozzle off the tray.
6. Carefully remove any mineral deposits from the tray.
7. Disconnect the drain hose from the drain fitting on the bottom of the humidifier housing.
8. Clean the drain fitting, if necessary.
9. Bend the drain hose to loosen any mineral deposits.
10. Flush the drain hose with pressurized water (a running tap) to clean the hose.
11. Reattach the drain hose to the drain fitting.
12. Snap the water nozzle back on the tray.
13. Be sure the black mark on the end of the pad is facing up. Place the tray on the new pad.

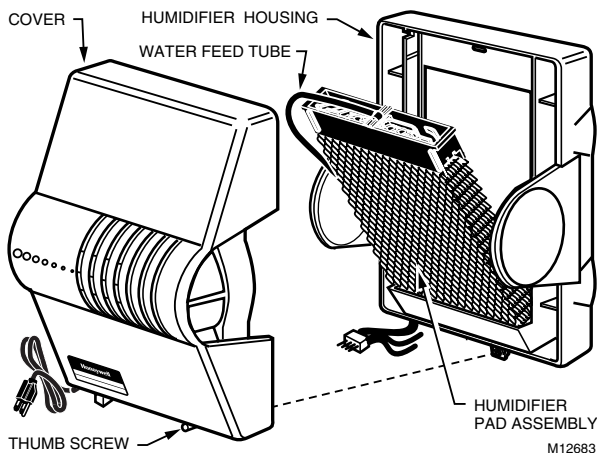

14. Place the humidifier pad assembly in the humidifier housing making sure the tabs on the end of the tray are placed in the slots on the humidifier housing. Be sure the water feed tube is placed in the guide slots.
15. Replace the humidifier cover.
16. Verify the humidifier operation by following the steps in the CHECKING THE HUMIDIFIER FOR PROPER OPERATION section.

End of Humidification Season

The humidifier needs to be cleaned and shut off at the end of the heating season. Use the EVERY 1 TO 3 MONTHS section steps 1 through 15 to shut down for the season.

IMPORTANT

Be sure the humidifier power is OFF.

Vacation

The humidifier water supply and your humidistat should be turned off. Turn on the humidifier water supply and reset your humidistat when you return.

CHECKING THE HUMIDIFIER FOR PROPER OPERATION

After winter startup or servicing, use the following steps to check the humidifier operation.

1. Turn on the humidifier power and water supply.
2. Turn the humidistat to its highest setting and set the thermostat to 10°F above the room temperature.
3. Observe that water is flowing out of the drain hose.

NOTE: The furnace blower must be running to activate the humidifier.

4. Reset the thermostat and humidistat to a comfortable setting for automatic operation.

TROUBLESHOOTING

Problem	What To Look For	What To Do
Low humidity	Furnace blower not operating	<ul style="list-style-type: none"> • Reset circuit breaker or check for blown fuse. • Check that the furnace power is on. • Check all external wiring connections. • Check the humidistat setting. • Call a professional heating contractor.
	Rapid air changes (Drafts: cold air is dry and is an added load to the humidifier.)	<ul style="list-style-type: none"> • Keep doors and windows closed. • Close fireplace damper when not in use. • Keep exhaust fan running time to a minimum. • Seal around doors and windows.
High humidity	Condensation on walls	<ul style="list-style-type: none"> • Turn humidistat and water off until condensation is completely evaporated.
	Heavy condensation on windows	<ul style="list-style-type: none"> • Turn humidistat down enough to eliminate condensation. This can be a temporary condition caused by moisture from bathing, mopping, cooking, etc. If moisture persists, more ventilation is needed.

Perfect Climate® CONTROLS FOR ADDED COMFORT AND CONVENIENCE

How it works...

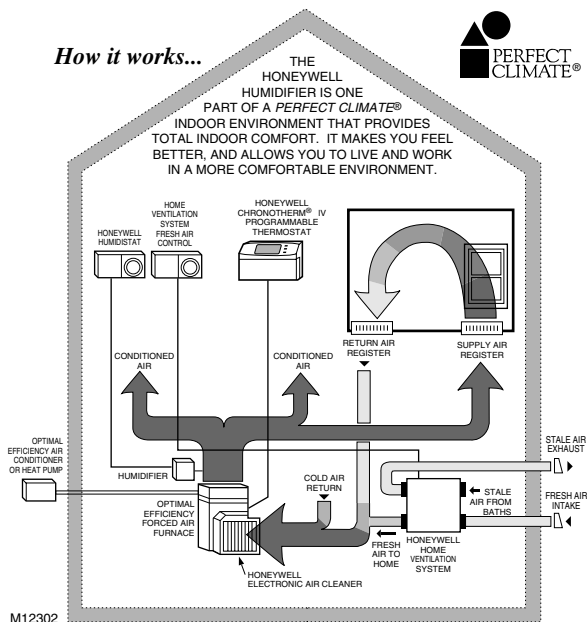

1. Honeywell Perfect Climate® Comfort Center™ controls or Chronotherm® IV programmable thermostats.
2. Honeywell F35 media air cleaner or F50 electronic air cleaners.
3. Honeywell humidistats.
4. Honeywell humidifiers.
5. Honeywell home ventilation systems.

Describing Perfection

The cleanest, healthiest, most convenient, energy efficient, and comfortable indoor environment possible today! Perfect climate is achieved when the five core components of a home's climate system work together:

- optimal efficiency heating and cooling equipment,
- precise, programmable temperature control,
- effective indoor air quality control,
- controlled humidity,
- proper ventilation and air distribution.

Contact your local Perfect Climate® dealer for an evaluation of your home.

WARRANTY

Honeywell warrants this product, excluding humidifier pad, to be free from defects in the workmanship or materials, under normal use and service, for a period of one (1) year from the date of purchase by the consumer. If, at any time during the warranty period, the product is defective or malfunctions, Honeywell shall repair or replace it (at Honeywell's option) within a reasonable period of time.

If the product is defective,

- (i) return it, with a bill of sale or other dated proof of purchase, to the retailer from which you purchased it, or
- (ii) package it carefully, along with proof of purchase (including date of purchase) and a short description of the malfunction, and mail it, postage prepaid, to the following address:

Honeywell Return Goods
Dock 4 MN10-3860
1885 Douglas Drive North
Golden Valley, MN 55422

This warranty does not cover removal or reinstallation costs. This warranty shall not apply if it is shown by Honeywell that the defect or malfunction was caused by damage which occurred while the product was in the possession of a consumer.

Honeywell's sole responsibility shall be to repair or replace the product within the terms stated above. HONEYWELL SHALL NOT BE LIABLE FOR ANY LOSS OR DAMAGE OF ANY KIND, INCLUDING ANY INCIDENTAL OR CONSEQUENTIAL DAMAGES RESULTING, DIRECTLY OR INDIRECTLY, FROM ANY BREACH OF ANY WARRANTY, EXPRESS OR IMPLIED, OR ANY OTHER FAILURE OF THIS PRODUCT. Some states do not allow the exclusion or limitation of incidental or consequential damages, so this limitation may not apply to you.

THIS WARRANTY IS THE ONLY EXPRESS WARRANTY HONEYWELL MAKES ON THIS PRODUCT. THE DURATION OF ANY IMPLIED WARRANTIES, INCLUDING THE WARRANTIES OF MERCHANTABILITY AND FITNESS FOR A PARTICULAR PURPOSE, IS HEREBY LIMITED TO THE ONE YEAR DURATION OF THIS WARRANTY. Some states do not allow limitations on how long an implied warranty lasts, so the above limitation may not apply to you.

This warranty gives you specific legal rights, and you may have other rights which vary from state to state.

If you have any questions concerning this warranty, please write our Customer Assistance Center MN 10-1461, Honeywell, 1885 Douglas Drive North, Golden Valley, MN 55442-4386. In Canada, write Retail Products, ON15-02H, Honeywell Limited/Honeywell Limitée, 35 Dynamic Drive, Scarborough, Ontario M1V 4Z9.

Honeywell

Home and Building Control

Honeywell Inc.
Honeywell Plaza
P.O. Box 524
Minneapolis, MN 55408-0524

Home and Building Control

Honeywell Limited-Honeywell Limitée
155 Gordon Baker Road
North York, Ontario
M2H 3N7



Printed in U.S.A. on recycled paper containing at least 10% post-consumer paper fibers.