

OWNER'S GUIDE

F50F  
**ELECTRONIC  
AIR CLEANER**





## **CONTENTS**

---

	<b>PAGE</b>
THE AIR CLEANER MONITOR	<b>2</b>
OPERATING YOUR ELECTRONIC AIR CLEANER	<b>3</b>
GETTING THE MOST FROM YOUR ELECTRONIC AIR CLEANER	<b>5</b>
CLEANING THE ELECTRONIC CELL(S) AND PREFILTER(S)	<b>7</b>
HOW ELECTRONIC AIR CLEANING WORKS	<b>13</b>
BEFORE YOU CALL FOR SERVICE	<b>18</b>
CLEAN COIL GUARANTEE	<b>20</b>
PERFECT CLIMATE <sup>®</sup>	<b>22</b>
WARRANTY	<b>23</b>

## AIR CLEANER MONITOR

---

The optional W8600F Air Cleaner Monitor may be added to your air cleaner system to provide convenient indication of system performance. The W8600F must be ordered separately.

The W8600F is designed to mount next to your thermostat, or in any convenient location (such as a utility room) where it can be seen as it monitors the air cleaner's performance.

The four Liquid Crystal Display (LCD) indicators are labeled ON, BATTERY, SERVICE and FAULT.

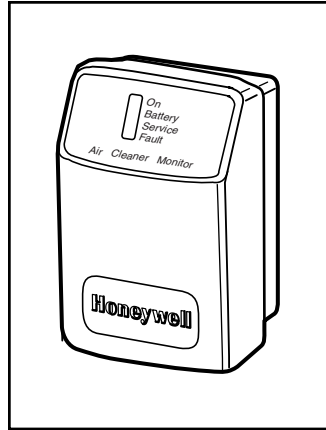

- The ON indicator is active during normal air cleaning operation. The system fan is also on when the air cleaner is running.
- The BATTERY indicator is active when the W8600F battery is low.
- The SERVICE indicator is active when it is time to wash the air cleaner prefilter(s) and cell(s). The time between cleanings is entered into the W8600F at installation. To turn the SERVICE indicator off, press the Reset button located at the bottom right of the W8600F.
- The FAULT indicator is active when there is extreme dirt loading, electronic malfunction, constant arcing or other problems with the high voltage output of the air cleaner power supply.

## OPERATING YOUR ELECTRONIC AIR CLEANER

---

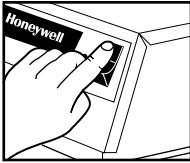

M3584

Set the ON-OFF switch in the power box to ON.

NOTE: Depress 1 for ON, 0 for OFF.

The air cleaner will now operate whenever your furnace/air conditioning system fan operates. For maximum air cleaning benefit and cleaner air conditioner coils, leave the air cleaner switch ON at all times and the fan switch on your thermostat ON. Of course, continuous fan operation will add to your electric bill each month.

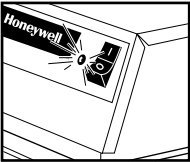

M3586

When the fan and air cleaner come on, the neon indicator lights.

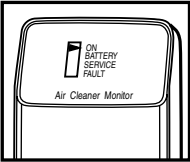

M11980

If your air cleaner is equipped with a wall-mounted W8600F Air Cleaner Monitor (see page 2), the ON indicator will be active *whenever the air cleaner is in operation*. Of course, the system fan will also be running.

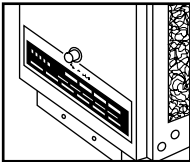

M 6032

You may hear a snapping (electrical arcing) sound occasionally as the air cleaner operates. This usually is caused by a larger dust particle causing a high voltage discharge. The snapping sound means that your air cleaner is working as it should. To hear the snapping sound, momentarily press the test button near the bottom of the door. Use the test button any time you want to prove air cleaner operation.

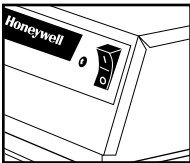

M3585

When the fan and air cleaner stops, the neon light goes out, as does the ON indicator on the W8600F. The air cleaner is off until the heating or air conditioning and fan start again.

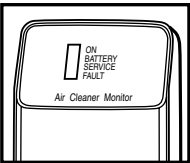

M11981

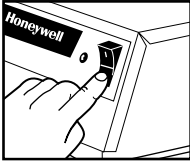

M3583

If you don't want the air cleaner to run, set the ON-OFF switch to OFF to turn off the air cleaner. Your furnace and air conditioner will still operate normally, but without the added benefit of air cleaning. Normally, this switch should be ON at all times.

---

## **GETTING THE MOST FROM YOUR ELECTRONIC AIR CLEANER**

---

### **Run the electronic air cleaner as much as possible**

For greatest benefit, the air cleaner should run all the time. To do this, set the fan switch on your thermostat to ON, and make sure the air cleaner is switched ON. The fan and air cleaner will run even when the furnace or air conditioner is off.

NOTE: A manual fan switch may be built into the furnace or furnace fan controller.

The air cleaner uses less power than a 40 watt light bulb (two-cell model—33 watts; single cell model—22 watts). The cost of running the system fan will vary with the size of your fan motor and the cost of electricity where you live. Most air cleaner owners feel that the added cost is more than offset by the added benefits of full time air cleaning and full time air circulation. You may feel that the room temperature stays more even when the fan is always on.

### **Keep the cell(s) and prefilter(s) clean**

Although the air cleaner is designed to be efficient over a wide range of cell dirt loading conditions, regular cleaning is your best assurance of consistent performance. Also, a very dirty cell and prefilter reduces air flow and, in turn, reduces the efficiency of the furnace or air conditioner. The cell wash reminder schedule or the optional W8600F Air Cleaner Monitor should be used to maintain a regular wash schedule.

### **Replace any activated carbon filters in the ductwork regularly**

An activated carbon (charcoal) filter is sometimes installed downstream of the air cleaner to help control odors. This filter should be changed at least annually, or as recommended by the filter manufacturer. Honeywell does not offer carbon filters for this application.

---

**If you have a humidifier**

If your system includes an atomizing humidifier, you may want to install a standard furnace filter between the humidifier and the air cleaner. This filter would keep the humidifier spray's mineral deposits from collecting on the air cleaner. This filter should be checked regularly and changed when it shows signs of mineral or dirt buildup. If you do not install a filter, you will probably need to wash the cell(s) and prefilter(s) more often to remove the mineral buildup.

If an ultrasonic room humidifier is used often, especially if filled with tap (undistilled) water, the cell(s) and prefilter(s) will require more frequent washing. A white residue will accumulate on the cell(s) from the minerals in the water. This residue may also contribute to "white dust" (see p. 17).

All Honeywell whole house humidifiers may be used in a system with the Honeywell Electronic Air Cleaner without any additional filters or system modification.



---

If your air cleaner has a W8600F Air Cleaner Monitor, the SERVICE indicator will activate when it is time to wash the cell(s) and prefilter(s). Wash them following the instructions starting on page 9. To turn the SERVICE indicator off, press the reset button on the lower right of the W8600F (see picture below).

You may consider washing your cell(s) and prefilter(s) before the SERVICE indicator activates if some activity in your home has changed. This can include, but is not limited to the following:

- Have the windows been open more often?
- Has someone been smoking more often?
- Has someone taken up a dust producing hobby?

If this activity change is permanent, you may want your installer to change the WASH schedule that was entered into the W8600F when it was installed.

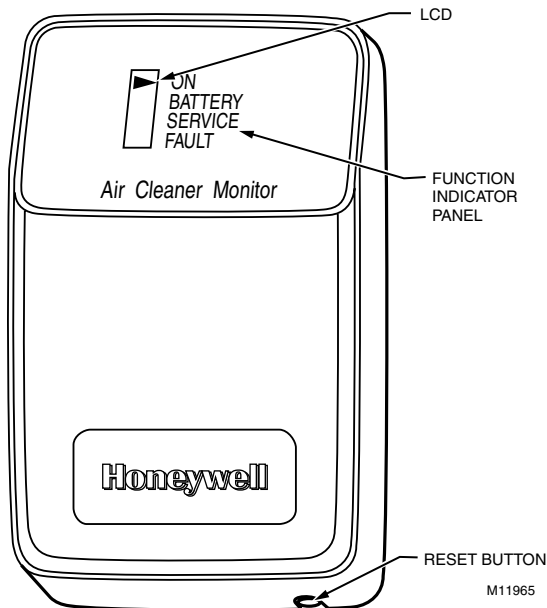

---

NOTE: You may let the heating or air conditioning system operate normally while the cell(s) are being washed. Simply turn off the air cleaner switch.

### Cleaning the prefilter(s)

Vacuum the prefilter or brush, or soak it in a tub. Do *not* wash the prefilter in the dishwasher or carwash.

### Washing the cell(s) in your automatic dishwasher



## CAUTION

### **Burn hazard.**

### **Can cause personal injury.**

Allow the cell(s) to cool completely in the dishwasher at the end of the wash cycle or wear protective gloves to avoid burns. Hot water can accumulate in the tubes supporting the collector plates. Tip the cell(s) so these tubes will drain.

### **IMPORTANT**

- *Check your dishwasher owner's manual. Some manufacturers do not recommend washing electronic cell(s) in their dishwashers.*
- *If the dishwasher has upper and lower arms, position the cell(s) carefully to allow good water circulation.*
- *Be careful to avoid damaging the cell(s) when placing them in the dishwasher. Broken ionizer wires or bent collector plates are not covered under the warranty.*
- *Very dirty cell(s), especially from tobacco or cooking smoke, can discolor the plastic parts and the lining of some dishwashers. This discoloration is not harmful. To minimize it, wash the cell(s) more frequently or try a different brand of detergent.*
- **Do NOT allow the dishwasher to run through the dry cycle.** *This will bake on any contaminants not removed during the wash cycle and reduce air cleaner efficiency.*

---

**STEP 1**

Put the cell(s) on the lower rack of the dishwasher with the airflow arrow pointing up. It may be necessary to remove the upper rack. Do not block water flow to the upper arm.

**HINT:** Lay a few large water glasses between the *spikes* on the lower rack, and rest the cell(s) on them so the *spikes* do not damage the aluminum collector blades.

**STEP 2**

Using your regular dishwashing detergent, allow the dishwasher to run through the complete wash and rinse cycle. **Do not use the dry cycle.** To avoid burns, let the cell(s) cool completely before removing, or wear protective gloves when removing the cell(s). Remember that water may be trapped inside the cell(s) plates. Tip the cell(s) so these tubes can drain.

**STEP 3**

Wipe the ionizer wires and contact board on the end of the cell using your thumb and forefinger with a small, damp cloth.

**STEP 4**

Inspect the dishwasher. You may wish to rerun the wash and/or rinse cycle with the dishwasher empty if you see dirt or residue from washing the cell(s). If dirt or residue seems excessive, wash the cell(s) more often or try a different detergent.

**Washing  
the  
cell(s) in  
a tub**



## **CAUTION**

**Hazardous chemical.**

**Can cause personal injury.**

- Do not splash the detergent solution in eyes. Wear rubber gloves to avoid prolonged detergent contact with your skin.
- Keep detergent and solution out of reach of children.

**NOTE:** Always wash the cell(s) first, then the prefilter(s), to keep heavy prefilter lint from getting caught in the cell(s).

- 
- STEP 1** Use a large enough container, such as a laundry tub or trash container, to hold one or both cell(s).
- NOTE: Sharp corners on the cell(s) can scratch the surface of a bathtub.
- STEP 2** Dissolve about 3/4 cup of automatic dishwasher detergent per cell in enough hot water to cover the cell(s). If the detergent does not dissolve readily, or forms a scum on the water, try another brand, or use softened water.
- STEP 3** After the detergent has completely dissolved, place the cell(s) in the container and let soak for 15 to 20 minutes. Agitate them up and down a few times, and remove.
- STEP 4** Next, wash the prefilter(s) the same way. Empty and rinse the wash container.
- STEP 5** Rinse the cell(s) and prefilter(s) with a hard spray of very hot water; rinse the tub clean, then fill the tub with clean hot water and soak for 5 to 15 minutes. Rinse until the water draining from the cell(s) and prefilter(s) no longer feels slippery.
- STEP 6** Soak cell(s) and prefilter(s) in a final clear water rinse for 10 minutes.
- STEP 7** Wipe the ionizer wires and contact board on the end of the cell using your thumb and forefinger with a small, damp cloth.
- Washing the cell(s) at a car wash** Use the hand sprayer at a coin-operated do-it-yourself car wash to wash the cell(s). Hold the nozzle at least two feet away from the unit to avoid damage (such as broken ionizer wires or bent collector plates) from the high pressure stream of water. Follow the same sequence of wash and rinse as recommended for cars. However, do not wax the cell(s). Be sure to rinse until the water draining from the cell(s) no longer feels slippery.

---

## Replacing electronic air cleaner components

- STEP 1**                    Inspect the cell(s) for broken ionizer wires and bent collector plates. Repair as necessary or take to a Honeywell Authorized Air Cleaner Repair Station.
- STEP 2**                    Slide the prefilter(s) into the upstream prefilter guides.
- STEP 3**                    Slide the air cleaner cell(s) in so the air flow arrow points downstream and the handle(s) face outward.
- STEP 4**                    Firmly close the access door.
- STEP 5**                    Turn on the air cleaner. If the cell(s) and prefilter(s) are wet, the neon light may not come on and you may hear arcing. If the arcing is annoying, simply turn the air cleaner off for 2-3 hours or until the cell(s) are dry.

If your air cleaner has an Air Cleaner Monitor, the FAULT indicator may activate if you install wet cell(s) and prefilter(s). Again, if the neon light or the FAULT indicator annoys you, simply turn off the air cleaner for 2-3 hours or until the cell(s) and prefilter(s) are dry.

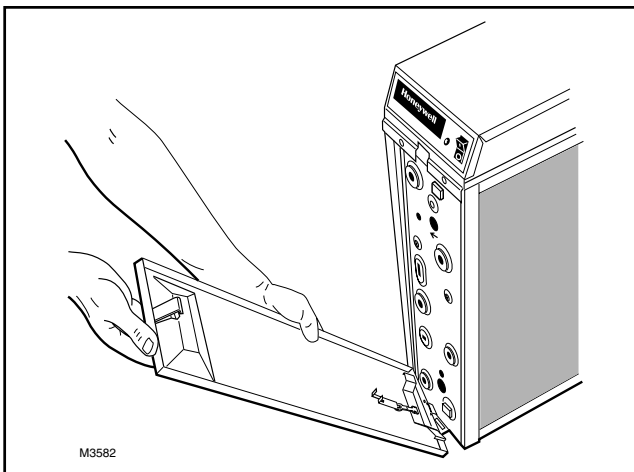

## HOW ELECTRONIC AIR CLEANING WORKS

### A word about particle size

The particles removed by the electronic air cleaner tend to be very small—less than 10 microns. But what is a 10 micron particle? Well, the eye of an average size sewing needle is about 750 microns across, and the dot in the *i* in the word micron is about 400 microns. Generally, particles smaller than 10 microns can be seen only with a microscope, except in very large concentrations, such as a puff of smoke. Your electronic air cleaner can remove even smaller particles that can be seen only with an electron microscope.

Although particles 1 micron and smaller make up only about 20 percent of the total *weight* of particles in unfiltered air, they account for over 99 percent of the *numbers* of particles.

Because they are so tiny, these particles tend to remain suspended in the air unless they collide with a solid surface. Then they attach by molecular adhesion and stick like glue, staining walls and furniture and coating your air conditioning coils. And of course, some of these particles can cause allergic reactions or simply make the environment less pleasant.

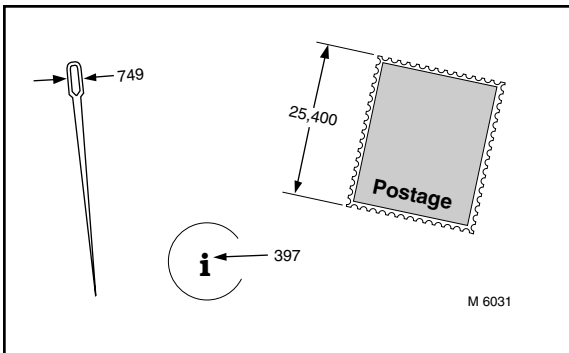

## How the electronic air cleaner works

First, large particles (lint, hair) are caught by the prefilter(s). Then, as the dirty air passes through the intense high voltage electric field surrounding the ionizer wires, all particles, even the smallest are given an electric charge. The air then passes into the collector where the alternate parallel plates are charged positive and negative, creating a uniform electrostatic field. Since opposites attract, the charged particles stick to the collector plates, which have an opposite electric charge. The air leaving the air cleaner contains very few particles.

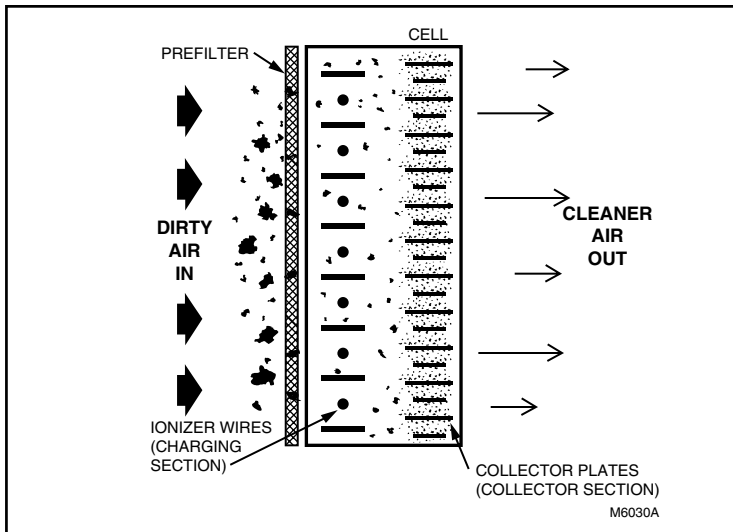

Each time the air circulates through the heating/air conditioning system and air cleaner, more particles are removed. These particles are generated by normal household activities, and also enter the house from outside. That is why we recommend that you use the air cleaner as much as possible.

---

**The electronic air cleaner vs. the standard furnace filter**

The regular furnace filter collects mainly large, visible particles that reach the filter. Its main purpose is to protect the furnace and air conditioner blower. The electronic air cleaner collects these large particles, plus many of the smaller, mostly invisible particles. Its purpose is to reduce indoor air pollution as well as to protect the blower, air conditioning coils and heat exchanger.

---

**Use a carbon filter to remove odors**

Odors are gases, not particles. They cannot be removed by the air cleaner or by any other filter designed to remove particles. However, some gases can be trapped by an activated carbon filter or diluted with outdoor air. If odors are a concern, talk to your heating and air conditioning dealer about installing a carbon filter downstream of the air cleaner or providing an outdoor air inlet.

**The electronic air cleaner versus the air ionizer**

Air ionizers have been marketed with claims about purifying the air and promising medical benefits. It should be noted that supporting tests, if available, are controversial and incomplete.

Air ionizers may generate a bit of ozone, and of course some ions (air molecules with an electric charge). This is what your electronic air cleaner's ionizer does, but with greater intensity. However, air ionizers do not have good collectors, if any. With air ionizers, the charged dirt particles are *collected* by walls, floor and furniture, requiring frequent cleaning of the entire building to remove the effects of collected contamination. By comparison, an electronic air cleaner deposits contamination on the cell(s) and prefilter(s) for easy cleaning.

**Ozone and the electronic air cleaner**

Electronic air cleaners generate a very small amount of ozone, about 0.005 to 0.010 parts per million (PPM). The amount is highest when the air cleaner is new.

The average person can detect the odor of ozone in concentrations as low as 0.003 to 0.010 PPM. The U.S. Food and Drug Administration, and Health and Welfare Canada recommend that indoor ozone concentration should not exceed 0.050 PPM. As a comparison, the outdoor ozone level in major cities is sometimes higher than 0.100 PPM.

---

**About lint or  
"white dust"**

If desired, the ozone generated by the air cleaner can be reduced by asking your dealer to:

- Install an activated carbon filter downstream of the air cleaner, or
- Adjust the air cleaner power supply to reduce ozone production. This adjustment will reduce ozone production about 20-25 percent, but will also reduce air cleaning efficiency about 7-10 percent.

White dust is made up of particles that settle out of the air before they get to the return air duct. You can help prevent this white dust from settling by running your fan constantly. Also:

- Be sure the return registers are not blocked with furniture.
- Be sure the discharge ducts are clean (best done before installing the air cleaner).
- Be sure your clothes dryer is vented to the outside and is not plugged.
- If you have new rugs or drapes or new woolen blankets, be aware that the lint from these items will reduce with age.
- In new or remodeled homes, plaster dust or paint pigment may contribute to *white dust*, but will reduce with time.
- Use of a humidifier may contribute to *white dust*, especially if filled with undistilled water.

## **BEFORE YOU CALL FOR SERVICE**

---

*If your air cleaner is equipped with the optional W8600F Air Cleaner Monitor, the SERVICE and FAULT indicator on the W8600F will remind you that a cell and prefilter washing is due and tell you when the system isn't operating properly. Whether or not your air cleaner has an Air Cleaner Monitor, perform these checks before you call your heating and air conditioning dealer for service.*

### **IF...**

### **THEN...**

**Electronic air cleaner doesn't seem to be working**

1. Make sure the furnace or air conditioner blower is running.
2. Make sure the access door is firmly closed and latched. If door is not closed properly, an interlock keeps the air cleaner off.
3. Press the test button. A snapping sound indicates the air cleaner is operating properly. If there is no snapping sound, make sure the appropriate fuse or circuit breaker is OK.

**Arcing (snapping) seems too frequent**

1. If the electronic cell(s) are wet from washing, turn the air cleaner off for 2-3 hours.
2. Check the cell(s) for broken ionizer wires or bent plates. Repair if necessary.
3. Wash cell(s) and prefilter(s) if dirty.

**The neon light on the air cleaner does not come on**

1. Make sure the furnace or air conditioner fan is running.
2. Make sure the access door is firmly closed.
3. Make sure the ON-OFF switch is in the ON position.
4. If the electronic cell(s) are wet, check again in 2 to 3 hours.

---

5. Press the test button. A snapping sound indicates the air cleaner is operating properly, but the neon light is not working. If there is no snapping sound, make sure the appropriate fuse or circuit breaker is OK.

**The SERVICE indicator on the W8600F activates**

1. Cell and prefilter washing is due; wash as soon as possible.

**The FAULT indicator on the W8600F activates**

1. Make sure cell(s) are clean and dry.
2. Check cells for visible damage.

**BATTERY Indicator on the W8600F activates**

1. Remove the cover from the W8600F, make sure the battery is firmly installed in holder.
2. Replace the disc battery with type BR2032.

**You smell ozone and find it objectionable**

Call your heating and air conditioning dealer.

## **HONEYWELL 10 YEAR CLEAN COIL GUARANTEE**

---

### **Guarantee**

Honeywell guarantees your indoor heating/cooling coil will maintain optimum efficiency and energy savings for a minimum of 10 years if your new Honeywell Electronic Air Cleaner is installed and properly maintained<sup>a</sup> on either...

- A *new* heat pump, air conditioner, or high efficiency furnace, or
- A heat pump, air conditioner, or high efficiency furnace that is less than *one year old*, or
- A heat pump, air conditioner, or high efficiency furnace more than one year old that has had the indoor coil *professionally cleaned by a qualified heating/cooling contractor* prior to installing a Honeywell Electronic Air Cleaner.

If your coil requires cleaning within the next 10 years, Honeywell will pay 50% of the cost to have the coil professionally cleaned by a qualified heating/cooling contractor, or \$100, whichever is less.

<sup>a</sup>Maintain electronic air cleaner operation by keeping power switch in the *ON* position, and periodically verifying proper operation by using the test button and checking the neon light. Wash cell(s) regularly, as specified earlier.

### **How to register your guarantee**

You can register your guarantee by filling out the Clean Coil Guarantee Registration Card on the back cover. If the card has been misplaced, follow registration instructions below. After Honeywell receives your registration, it will be filed; no confirmation will be sent.

To register your guarantee you'll need a copy of your dealer invoice showing purchase of a Honeywell Electronic Air Cleaner. You will also need dealer invoice(s) verifying the purchase of new heating/cooling equipment, or coil cleaning on existing equipment. The registration procedure differs for new and existing equipment.

---

**...on new equipment or equipment less than one year old**

For Honeywell Electronic Air Cleaners installed on a heat pump, air conditioner or high efficiency furnace that is either *new or less than one year old*, send copies of invoices verifying...

- Purchase of a new Honeywell Electronic Air Cleaner.
- Purchase of a heat pump, air conditioner or high efficiency furnace that is new or less than one year old.

**...in newly constructed homes**

Honeywell recognizes that in some newly constructed homes (those built within the previous twelve months) a Honeywell Electronic Air Cleaner may have already been installed, with no invoice available. In that case, register your guarantee by sending in the following...

- The name, address and phone number of the home builder.
- The approximate date home was completed.
- The date you moved in.

**...on existing equipment more than one year old**

For Honeywell Electronic Air Cleaners installed on a heat pump, air conditioner or high efficiency furnace that is *more than one year old*, send copies of invoices verifying...

- Proof of purchase of a new Honeywell Electronic Air Cleaner.
- Proof of purchase of a professional coil cleaning by a qualified heating/cooling contractor.

# Perfect Climate® CONTROLS FOR ADDED COMFORT AND CONVENIENCE

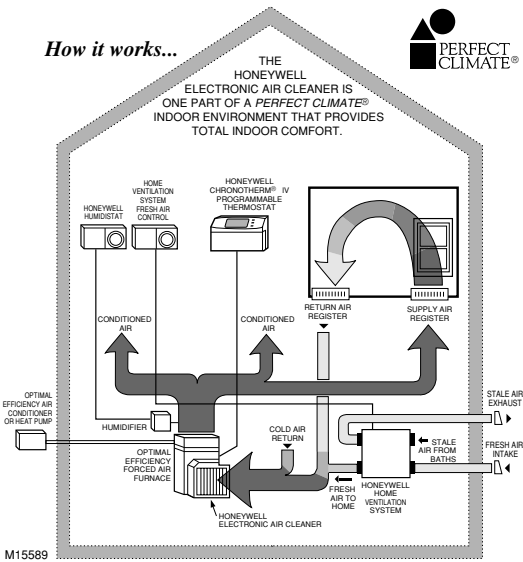

1. Honeywell Perfect Climate® Comfort Center™ controls or Chronotherm® IV programmable thermostats.
2. Honeywell F50 electronic air cleaner.
3. Honeywell humidistats.
4. Honeywell humidifiers.
5. Honeywell home ventilation systems.

## Describing Perfection

The most convenient, most energy efficient, cleanest, healthiest and most comfortable indoor environment possible today! Perfect climate is achieved when the five core components of a home's climate system work together:

- optimal efficiency heating and cooling equipment,
- precise, programmable temperature control,
- effective indoor air quality control,
- controlled humidity,
- proper ventilation and air distribution.

Contact your local Perfect Climate® dealer for an evaluation of your home.

## **LIMITED FIVE-YEAR WARRANTY**

---

Honeywell warrants this product to be free from defects in the workmanship or materials, under normal use and service, for a period of five (5) years from the date of purchase by the consumer. If, at any time during the warranty period, the product is defective or malfunctions, Honeywell shall repair or replace it (at Honeywell's option) within a reasonable period of time.

If the product(s) is defective, please contact:

- a) the dealer from whom you purchased it, or
- b) the local Honeywell Authorized Repair Station, or
- c) the local Honeywell Residential Division Sales Office,  
or
- d) package the defective cell, power supply or other component with care, along with a bill of sale, receipt, or other dated proof of purchase, and a short description of the malfunction, and ship it, prepaid, to the following address:

Honeywell Return Goods  
Dock 4 MN10-3860  
1885 Douglas Drive  
Golden Valley, MN 55422

This warranty does not cover removal or reinstallation costs. This warranty shall not apply if it is shown by Honeywell that the defect or malfunction was caused by damage which occurred while the product was in the possession of a consumer.

Honeywell's sole responsibility shall be repair or replace the product within the terms stated above. HONEYWELL SHALL NOT BE LIABLE FOR ANY LOSS OR DAMAGE OF ANY KIND, INCLUDING ANY INCIDENTAL OR CONSEQUENTIAL DAMAGES RESULTING, DIRECTLY OR INDIRECTLY, FROM ANY BREACH OF ANY WARRANTY, EXPRESS OR IMPLIED, OR ANY OTHER FAILURE OF THIS PRODUCT. Some states do not allow the exclusion or limitation of incidental or consequential damages, so this limitation may not apply to you.

THE WARRANTIES SET FORTH HEREIN ARE EXCLUSIVE, AND HONEYWELL EXPRESSLY DISCLAIMS ALL OTHER WARRANTIES, WHETHER WRITTEN, ORAL, IMPLIED OR STATUTORY, INCLUDING BUT NOT LIMITED TO ANY WARRANTIES OF MERCHANTABILITY, WORKMANSHIP, OR FITNESS FOR A PARTICULAR PURPOSE.

This warranty gives you specific legal rights, and you may have other rights which vary from state to state.

If you have any questions concerning this warranty, please write to Home and Building Control Customer Relations, Honeywell, 1985 Douglas Drive North, Minneapolis, Minnesota 55422. In Canada, Honeywell Limited/Honeywell Limitée, 35 Dynamic Drive, Scarborough, Ontario M1V 4Z9.





# Honeywell

---

## Home and Building Control

Honeywell Inc.

Honeywell Plaza

P.O. Box 524

Minneapolis, MN 55408-0524

69-0756—2 J.H. Rev. 5-98



Printed in U.S.A. on recycled paper containing at least 10% post-consumer paper fibers.

[www.honeywell.com/  
yourhome](http://www.honeywell.com/yourhome)